

Drive Naming Rules

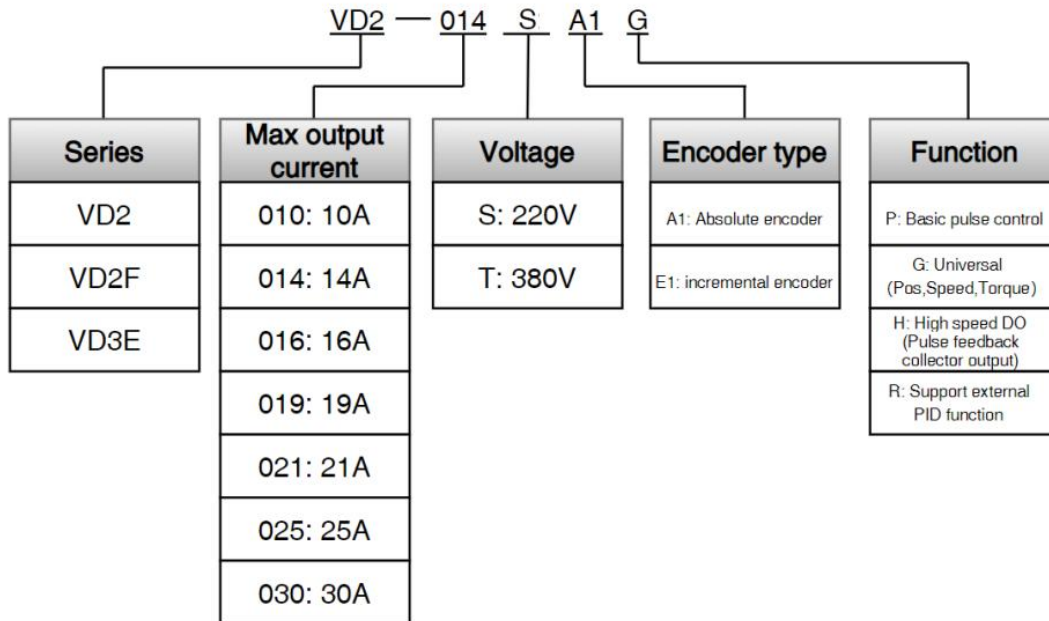

Motor Naming Rules

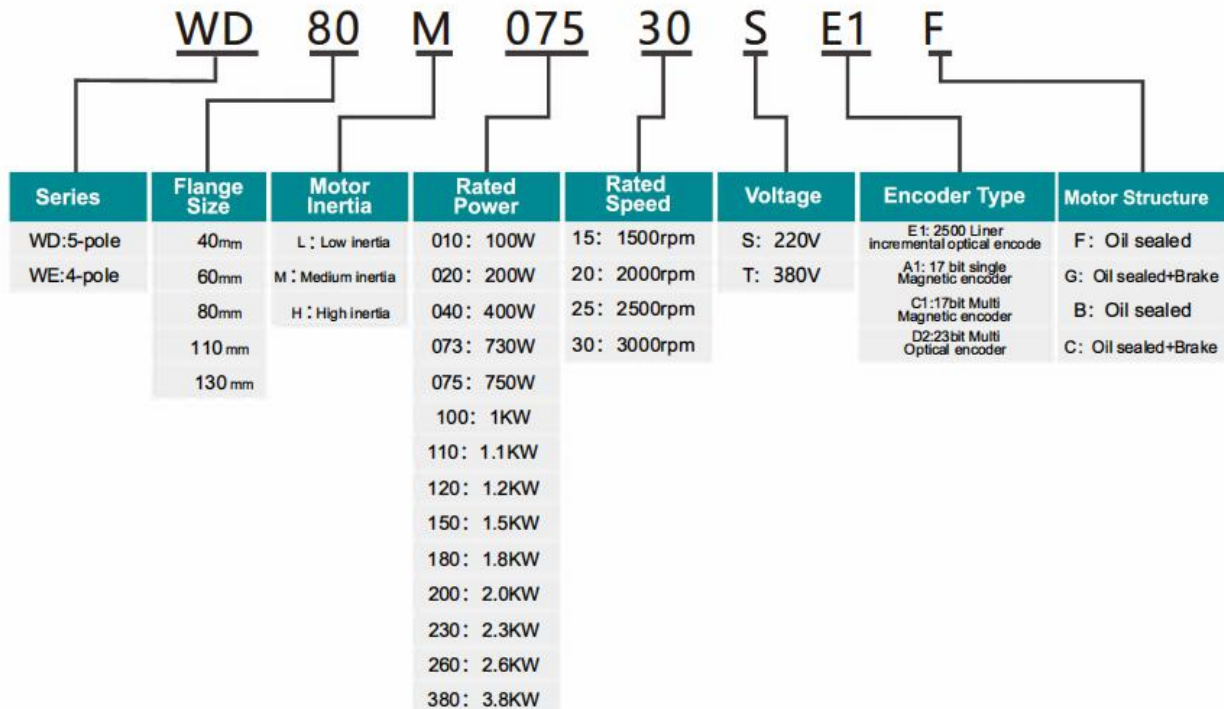

VD2 17 bit Absolute Single-turn Magnetic Encoder

Flange Size	Motor Model	Drive Model	Rated Torque (N.m)	Rated Speed (rpm)	Voltage
80	WE80M-11030S-A1F	VD2-016SA1G	3.5	3000	220V
		VD2-016SA1H	3.5	3000	220V
80	WE80M-10025S-A1F	VD2-016SA1G	4	2500	220V
		VD2-016SA1H	4	2500	220V
80	WE80M-12030S-A1F	VD2-016SA1G	4	3000	220V
		VD2-016SA1H	4	3000	220V
110	WE110M-12030S-A1F	VD2-016SA1G	4	3000	220V
		VD2-016SA1H	4	3000	220V
110	WE110M-15030S-A1F	VD2-019SA1G	5	3000	220V
		VD2-019SA1H	5	3000	220V
110	WE110M-18030S-A1F	VD2-019SA1G	6	3000	220V
		VD2-019SA1H	6	3000	220V
130	WE130M-10025S-A1F	VD2-016SA1G	4	2500	220V
		VD2-016SA1H	4	2500	220V
130	WE130M-13025S-A1F	VD2-016SA1G	5	2500	220V
		VD2-016SA1H	5	2500	220V
130	WE130M-15025S-A1F	VD2-019SA1G	6	2500	220V
		VD2-019SA1H	6	2500	220V
130	WE130M-20025S-A1F	VD2-021SA1G	7.7	2500	220V
		VD2-021SA1H	7.7	2500	220V
130	WE130M-15015S-A1F	VD2-016SA1G	10	1500	220V
		VD2-016SA1H	10	1500	220V
130	WE130M-26025S-A1F	VD2-021SA1G	10	2500	220V
		VD2-021SA1H	10	2500	220V
130	WE130M-23015S-A1F	VD2-019SA1G	15	1500	220V
		VD2-019SA1H	15	1500	220V
130	WE130M-38025S-A1F	VD2-021SA1G	15	2500	220V
		VD2-021SA1H	15	2500	220V
130	WE130M-20025T-A1F	VD2-021TA1G	7.7	2500	380V
130	WE130M-26025T-A1F	VD2-021TA1G	10	2500	380V
130	WE130M-38025T-A1F	VD2-021TA1G	15	2500	380V
130	WE130M-42020T-A1F	VD2-021TA1G	20	2000	380V
130	WE130M-53030T-A1F	VD2-021TA1G	17	3000	380V



VD2 17 bit Absolute Multi-turn Magnetic Encoder

Flange Size	Motor Model	Drive Model	Rated Torque (N.m)	Rated Speed (rpm)	Voltage
80	WE80M-11030S-C1F	VD2-016SA1G	3.5	3000	220V
		VD2-016SA1H	3.5	3000	220V
80	WE80M-12030S-C1F	VD2-016SA1G	4	3000	220V
		VD2-016SA1H	4	3000	220V
110	WE110M-12030S-C1F	VD2-016SA1G	4	3000	220V
		VD2-016SA1H	4	3000	220V
110	WE110M-15030S-C1F	VD2-019SA1G	5	3000	220V
		VD2-019SA1H	5	3000	220V
110	WE110M-18030S-C1F	VD2-019SA1G	6	3000	220V
		VD2-019SA1H	6	3000	220V
130	WE130M-10025S-C1F	VD2-016SA1G	4	2500	220V
		VD2-016SA1H	4	2500	220V
130	WE130M-13025S-C1F	VD2-016SA1G	5	2500	220V
		VD2-016SA1H	5	2500	220V
130	WE130M-15025S-C1F	VD2-019SA1G	6	2500	220V
		VD2-019SA1H	6	2500	220V
130	WE130M-20025S-C1F	VD2-021SA1G	7.7	2500	220V
		VD2-021SA1H	7.7	2500	220V
130	WE130M-15015S-C1F	VD2-016SA1G	10	1500	220V
		VD2-016SA1H	10	1500	220V
130	WE130M-26025S-C1F	VD2-021SA1G	10	2500	220V
		VD2-021SA1H	10	2500	220V
130	WE130M-23015S-C1F	VD2-019SA1G	15	1500	220V
		VD2-019SA1H	15	1500	220V
130	WE130M-38025S-C1F	VD2-021SA1G	15	2500	220V
		VD2-021SA1H	15	2500	220V
130	WE130M-20025T-C1F	VD2-021TA1G	7.7	2500	380V
130	WE130M-26025T-C1F	VD2-021TA1G	10	2500	380V

130	WE130M-38025T-C1F	VD2-021TA1G	15	2500	380V
130	WE130M-53030T-C1F	VD2-021TA1G	17	3000	380V

VD2 23 bit Absolute Multi-turn Optical Encoder

Flange Size	Motor Model	Drive Model	Rated Torque (N.m)	Rated Speed (rpm)	Voltage
80	WE80M-11030S-D2F	VD2-016SA1G	3.5	3000	220V
		VD2-016SA1H	3.5	3000	220V
80	WE80M-12030S-D2F	VD2-016SA1G	4	3000	220V
		VD2-016SA1H	4	3000	220V
110	WE110M-12030S-D2F	VD2-016SA1G	4	3000	220V
		VD2-016SA1H	4	3000	220V
110	WE110M-15030S-D2F	VD2-019SA1G	5	3000	220V
		VD2-019SA1H	5	3000	220V
110	WE110M-18030S-D2F	VD2-019SA1G	6	3000	220V
		VD2-019SA1H	6	3000	220V
130	WE130M-10025S-D2F	VD2-016SA1G	4	2500	220V
		VD2-016SA1H	4	2500	220V
130	WE130M-13025S-D2F	VD2-016SA1G	5	2500	220V
		VD2-016SA1H	5	2500	220V
130	WE130M-15025S-D2F	VD2-019SA1G	6	2500	220V
		VD2-019SA1H	6	2500	220V
130	WE130M-20025S-D2F	VD2-021SA1G	7.7	2500	220V
		VD2-021SA1H	7.7	2500	220V
130	WE130M-15015S-D2F	VD2-016SA1G	10	1500	220V
		VD2-016SA1H	10	1500	220V
130	WE130M-26025S-D2F	VD2-021SA1G	10	2500	220V
		VD2-021SA1H	10	2500	220V
130	WE130M-23015S-D2F	VD2-019SA1G	15	1500	220V
		VD2-019SA1H	15	1500	220V
130	WE130M-38025S-D2F	VD2-021SA1G	15	2500	220V
		VD2-021SA1H	15	2500	220V
130	WE130M-26025S-D2F	VD2-021SA1G	10	2500	220V
		VD2-021SA1H	10	2500	220V
130	WE130M-38025S-D2F	VD2-021SA1G	15	2500	220V
		VD2-021SA1H	15	2500	220V
130	WE130M-20025T-D2F	VD2-021TA1G	7.7	2500	380V
130	WE130M-26025T-D2F	VD2-021TA1G	10	2500	380V
130	WE130M-38025T-D2F	VD2-021TA1G	15	2500	380V
130	WE130M-53030T-D2F	VD2-021TA1G	17	3000	380V
180	WE180M-30015T-D2F	VD2-021TA1G	19	1500	380V
180	WE180M-43015T-D2F	VD2-021TA1G	27	1500	380V
180	WE180M-55015T-D2F	VD2-021TA1G	35	1500	380V

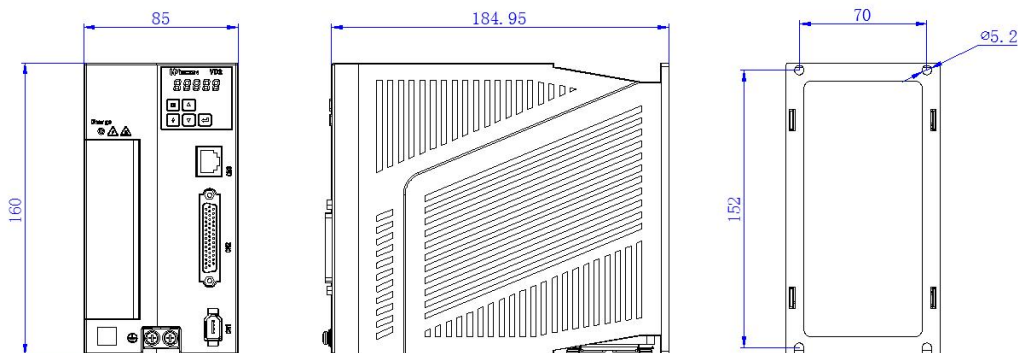

SPECIFICATION

Item		VD2 Series	
Basic Specifications	Voltage	220V / 380V	
	Control Method	IGBT PWM controlled sine wave current drive	
	Encoder	2500ppr incremental encoder; 17 bit, 23 bit absolute encoder	
	Input Signal	8*DI	
	Output Signal	4*DO	
	Analog Signal Input	2*AI input(-10v~10v)	
	Pulse Signal Input	Open collector or differential input	
	Pulse Feedback Output	A,B,Z differential output	
	Internal Instructions	Support 8 internal speed commands and internal multi-segment position commands	
	Communication/Debug	Support to communicate with modbus device and debug with SCTools at the same time. (SCTools can set&monitor servo parameters,monitor waveform,self-tuning parameter,etc.)	
	Braking Resistor	400W without built-in baking resistor; both support external braking resistor	
Function Setting	General Function	Self-tuning	SCTools supports self-tuning function,and identifies load inertia identification and rigidity level, and other parameters.
		Waveform Monitoring	View position, speed, torque and other curves on PC in real time
		Waveform Storage	The original waveform data could be stored for up to 10s
		Parameter Import / Export	Support batch parameter import and export; support PLC configurate servo parameters automatically (supported by some models)
		Vibration Suppression	Suppress mechanical vibration by setting vibration suppression parameters
		Protective Function	Overvoltage, undervoltage, overcurrent, overspeed, overload, overheating, encoder failure, excessive position deviation, torque limit, speed limit, etc
		Brake	Support
		Universal Control DI	Servo enable (SON), fault and warning clear (A-CLR), forward drive prohibition (POT), reverse drive prohibition (NOT), command reverse (C-SIGN), emergency stop (E-STOP), Gain switching (GAIN-SEL), Multi-speed command selection(INSPD1、 INSPD2、 INSPD3) ; Internal multi-position command selection and enable (POS1,POS2, POS3,POS4, POSEN)
		Universal Control DO	Servo ready (RDY), fault signal (ALM), warning signal (WARN), rotation detection (TGON), zero speed signal (ZSP), torque limit (T-LIMIT), speed limit (V-LIMIT),servo on state output (SRV-ST), servo brake output (BRK-OFF)
	Pulse Input	Pulse Frequency	Maximum 500khz
		Pulse Type	Pulse + Direction, CCW/CW pulse, Quadraturel encoding
		Pulse Filtering	First-order low-pass filter or smooth filter
		Pulse Output	Differential Quadraturel encoding A, B, Z output; PPR is settable by p0-16 or P0-17~P0-20.
	Speed Mode	Command Input	-10V~+10V analog input internal speed command (Maximum 8)
		Zero Clamp	Motor speed could be clamped to zero via the setting of zero clamp function
		Torque Limit	Support to set the torque limit
	Torque Mode	Command Input	-10V~+10V analog input and Internal torque command
		Torque Reaching	Torque reaching threshold and DO can be set flexibly
		Speed Limit	The speed limit can be set flexibly

80 Series Motor Specification

Motor model	WD80M-11030S ^{★△}	WD80M-10025S ^{★△}	WD80M-12030S ^{★△}
Rated power (kW)	1.1	1	1.2
Rated torque (N·m)	3.5	4	4
Rated speed (r/min)	3000	2500	3000
Brake	Optional	Optional	Optional
LA without Brake (mm)	179	191	191
LA with Brake (mm)	221	233	233

Remark:

★ : A1-17 bit single Magnetic encoder; C1-17 bit Multi Magnetic encode; D2- 23bit Multi Optical encoder

△ : F-sealed; G-sealed & Brake

-L: Connector type

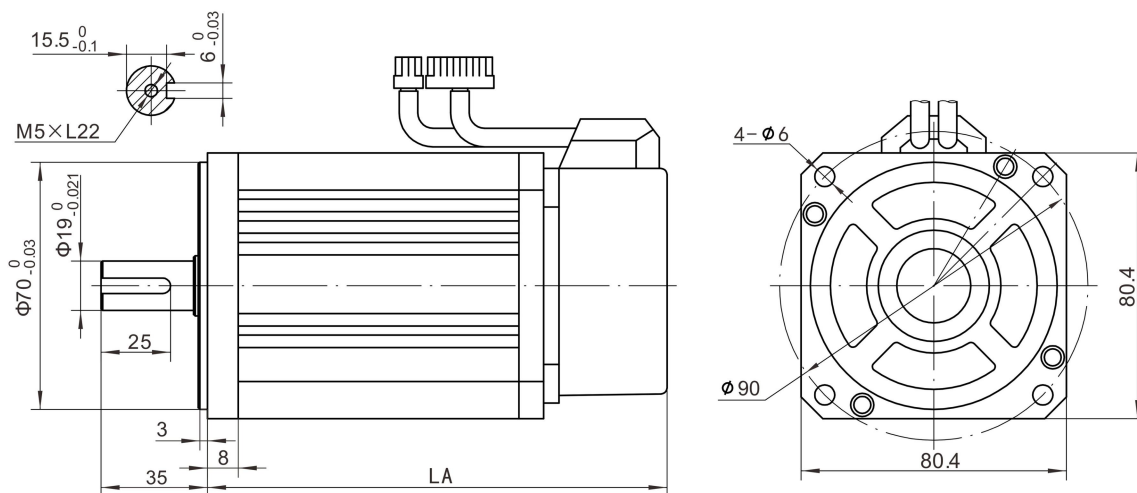

110 Series Motor Specification

Motor model	WE110M-12030S [★] △	WE110M-15030S [★] △	WE110M-18030S [★] △
Rated power (kW)	1.2	1.5	1.8
Rated torque (N·m)	4	5	6
Rated speed (r/min)	3000	3000	3000
Brake	Optional	Optional	Optional
LA without Brake (mm)	189	204	219
LA with Brake (mm)	254	269	284

Remark:

★ : A1-17 bit single Magnetic encoder; C1-17 bit Multi Magnetic encode; D2- 23bit Multi Optical encoder

△ : F-sealed; G-sealed & Brake

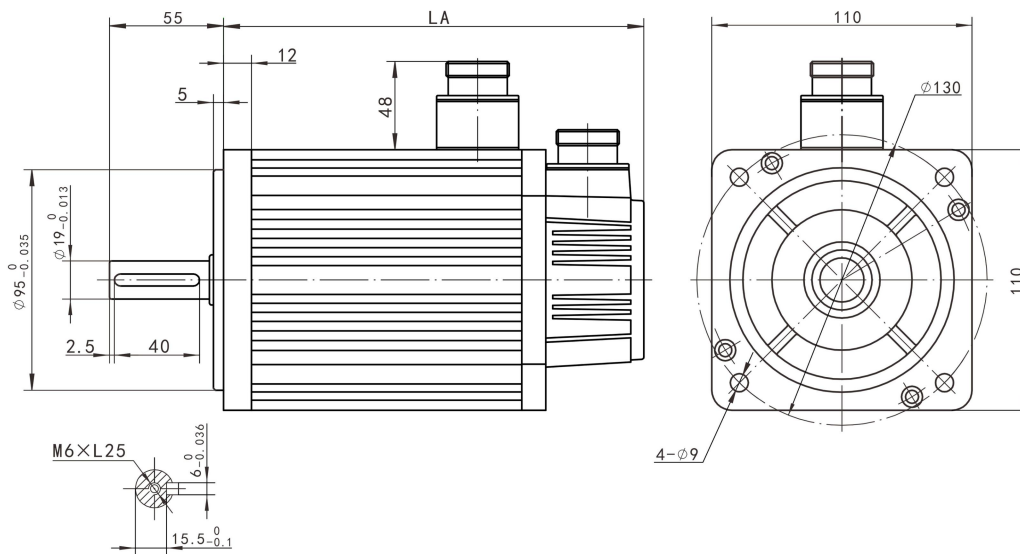

130 Series Motor Specification

Motor model	WE130M-10025S★△	WE130M-13025S★△	WE130M-15025S★△	WE130M-20025S★△
Rated power (kW)	1.0	1.3	1.5	2.0
Rated torque (N·m)	4	5	5	7.7
Rated speed (r/min)	2500	2500	2500	2500
Brake	Optional	Optional	Optional	Optional
LA without Brake (mm)	166	171	171	192
LA with Brake (mm)	226	231	231	252

Motor model	WE130M-15015S★△	WE130M-26025S★△	WE130M-23015S★△	WE130M-38025S★△
Rated power (kW)	1.5	2.6	2.3	3.8
Rated torque (N·m)	10	10	15	15
Rated speed (r/min)	1500	2500	1500	2500
Brake	Optional	Optional	Optional	Optional
LA without Brake (mm)	213	213	241	231
LA with Brake (mm)	279	279	304	294

Remark:

★ : A1-17 bit single Magnetic encoder; C1-17 bit Multi Magnetic encode; D2- 23bit Multi Optical encoder

△ : F-sealed; G-sealed & Brake

-L: Connector type

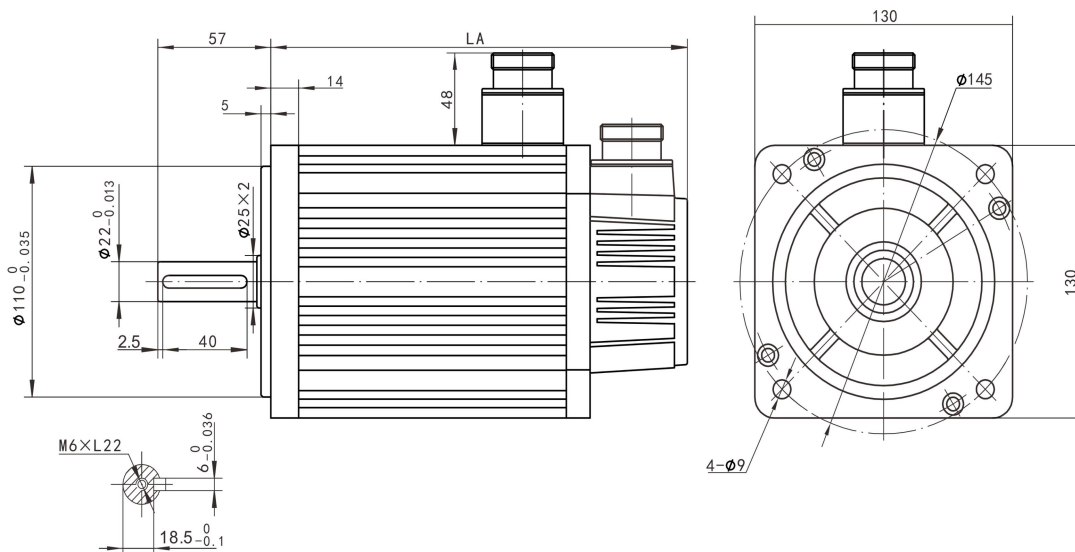

130 Series Motor Specification

Motor model	WE130M-20025T ^{★△}	WE130M-26025T ^{★△}	WE130M-38025T ^{★△}
Rated power (kW)	2.0	2.6	3.8
Rated torque (N·m)	7.7	10	15
Rated speed (r/min)	2500	2500	2500
Brake	Optional	Optional	Optional
LA without Brake (mm)	192	213	231
LA with Brake (mm)	252	279	294

Remark:

★ : A1-17 bit single Magnetic encoder; C1-17 bit Multi Magnetic encode; D2- 23bit Multi Optical encoder

△ : F-sealed; G-sealed & Brake

-L: Connect

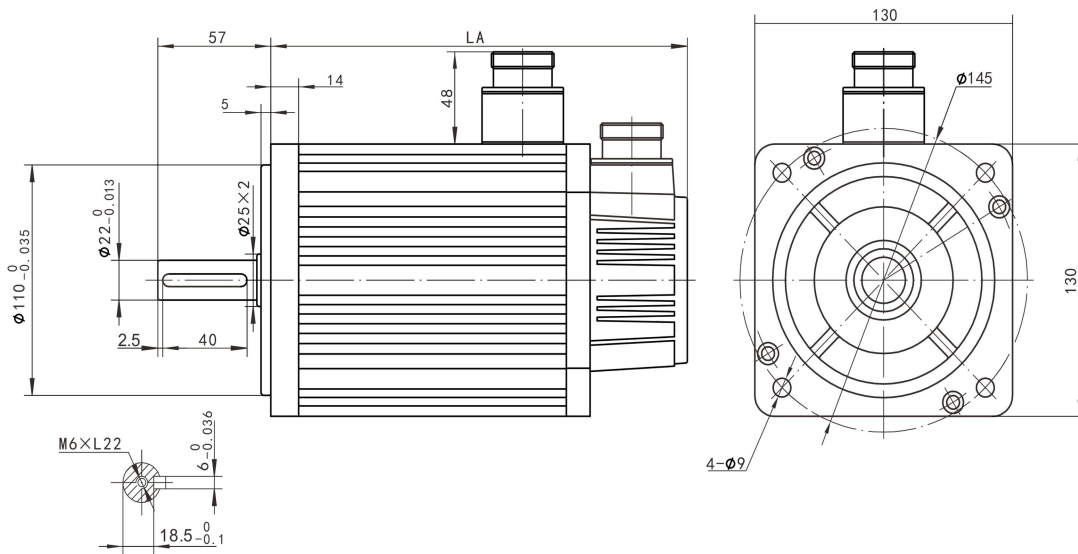

180 Series Motor Specification

Motor model	WE180M-30015T★△	WE130M-43015T★△	WE130M-55015T★△
Rated power (kW)	3.0	4.3	5.5
Rated torque (N·m)	19	27	35
Rated speed (r/min)	1500	1500	1500
Brake	Optional	Optional	Optional
LA without Brake (mm)	226	362	292
LA with Brake (mm)	298	334	364

Remark:

★ : A1-17 bit single Magnetic encoder; C1-17 bit Multi Magnetic encode; D2- 23bit Multi Optical encoder

△ : F-sealed; G-sealed & Brake

-L: Connect

